



MICROBE NINJA™

Hypochlorous Acid Generators

NinjaGen 360

**Producing a powerful
HOCl solution on-site
has never been easier!**



The NinjaGen model 360

The Microbe Ninja™ NinjaGen 360 is a stand-alone, on-site generator optimized to produce hypochlorous acid with an adjustable pH. Using Microbe Ninja technology the system converts salt, water and electricity into an effective and powerful solution that can substitute for a number of conventional chemicals used on a daily basis. This translates to a strong supply chain and savings over time. Keeping your business operating smoothly is easy with the NinjaGen.

Uses

- Kills bacteria⁽¹⁾
- Kills viruses⁽²⁾
- Sanitizes⁽³⁾ hard surfaces
- Cleans multiple surface types
- Any situation where sodium hypochlorite or calcium hypochlorite have traditionally been used.

Skid dimensions and weight	
Depth x Width x Height	19" x 36" x 60"
Weight	130 lbs.
Shipping dimensions and weight (Crate)	
Depth x Width x Height (crate)	24" x 40" x 70"
Weight	326 lbs.
Pallet with salt & vinegar feeder	40" x 48" x 30"
Pallet weight	82 lbs.
Harmonized tariff code	8421.21.00
Electrical requirements	
Max AC primary amps	8amps @ 110v
Voltage / Hz	110-240v 50/60Hz
Phase	Single
Breaker required	15 amp

Generator performance	500ppm FAC	1,000ppm FAC
Water flow	0.6 gpm	0.25gpm
Water pressure (min)	25psi (2 Bar)	
Water pressure (max)	50psi (4 Bar)	
Water softener required	No	No
Hypochlorous acid produced	864 gallons / day	360 gallons / day
pH of solution (4 options)	5.5 / 6.0 / 6.5 / 7.0	
FAC of generated solution	>500ppm	>1,000ppm
Estimated salt usage (lbs. used / gal. produced)	21.5 lbs. / 864 gal.	9.7 lbs. / 360 gal.
At ph 6.0 Estimated vinegar usage (Diluted gal. used / gal. produced)	3.3 gal. / 864 gal.	2.6 gal. / 360 gal.
Specifications		
Power supply	50amp 24v DC switch mode	
Electrode stack (cell)	10,000 - 15,000 hour reverse polarity	
Operating temperature (Air)	45°F - 115°F (7°C - 46°C)	
Operating temperature (Water)	50°F - 80°F (10°C - 26°C)	

(1) Bacterias tested by third party labs [PASS, 10 MCT]: Pseudomonas Aeruginosa (ATCC 15442), Staphylococcus Aureus (ATCC 6538)

(2) Viruses tested by third party labs [Log Reduction > 4.25, 10 MCT]: Rhinovirus 37 (Strain 151-1 ATCC VR-1607), Adenovirus 5 (Strain Adenoid 75, ATCC VR-5), Phi6 Bacteriophage

(3) Sanitizer for use on hard surfaces, Staphylococcus Aureus (ATCC 6538), 1 MCT.

SKID MOUNTED NINJAGEN 360

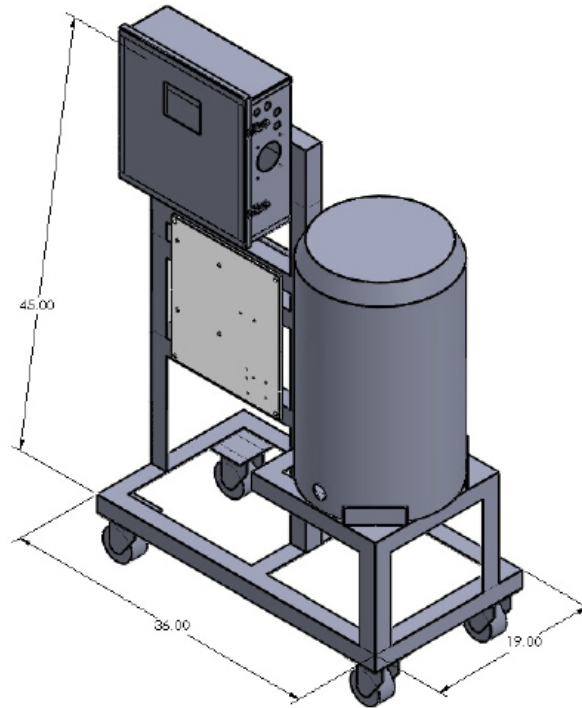

ACID / VINEGAR FEEDER

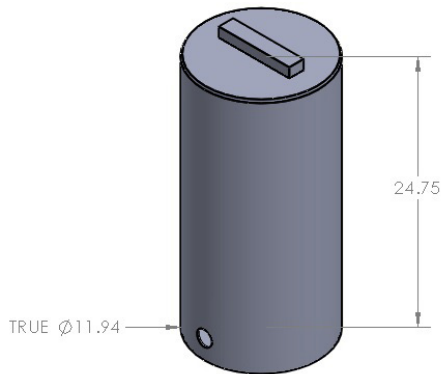

SALT FEEDER

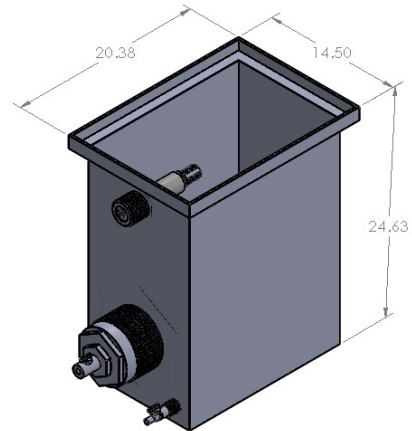

NOTE: The customer is responsible for sourcing the pelleted salt (99% purity) and the vinegar (30%) required to run the HYPOGEN.

Microbe Ninja™ is leading the way in commercial saline chlorination with environmentally friendly solutions changing the way we treat H₂O.

Microbe Ninja™ 9361 Irvine Boulevard Irvine, CA 92618 USA
info@microbeninja.com 888.664.6525 microbeninja.com

**A Division of Diamon-Fusion, International*

